

ALL DRAWINGS, PLANS, AND SPECIFICATIONS ARE PROPERTY OF SCURLOCK DRAFTING & DESIGN. PURCHASER'S RIGHT IS CONDITIONAL AND LIMITED TO A ONE-TIME USE TO CONSTRUCT A SINGLE PROJECT ON THE LOT STATED HEREIN. THE USE OF OR REPRODUCTION OF THESE PLANS CONCERNING ANY OTHER CONSTRUCTION IS STRICTLY PROHIBITED. SCURLOCK DRAFTING & DESIGN IS NOT AN ENGINEERING FIRM NOR AN ARCHITECTURAL FIRM. SCURLOCK DRAFTING & DESIGN IS NOT QUALIFIED NOR LICENSED TO DESIGN STRUCTURAL FRAMING OR FOUNDATIONS. A LICENSED PROFESSIONAL ENGINEER SHOULD BE CONSULTED REGARDING STRUCTURAL FRAMING AND FOUNDATIONS. SHOULD AN ENGINEER'S SEAL BE PRESENT ON THE DRAWING, THEN THE "ENGINEER OF RECORD" SHALL BEAR THE SOLE RESPONSIBILITY FOR THE STRUCTURAL DESIGN. SCURLOCK DRAFTING & DESIGN WILL NOT BE HELD RESPONSIBLE FOR THE STRUCTURAL DESIGN AND/OR ANY PROBLEMS THAT MAY ARISE REGARDING THE DESIGN.

SCURLOCK DRAFTING ASSUMES NO LIABILITY FOR ANY HOME BUILT FROM THESE PLANS. IT IS THE RESPONSIBILITY OF THE BUILDER OF THESE PLANS TO PERFORM THE FOLLOWING BEFORE CONSTRUCTION BEGINS.

- VERIFY/BUILD TO LOCAL AND STATE CODES.
- ALL DIMENSIONS ARE TO BE CHECKED AND VERIFIED BEFORE CONSTRUCTION.
- VERIFY WINDOW SIZES WITH WINDOW MANUFACTURER FOR COMPLIANCE WITH INGRESS/EGRESS REQUIREMENTS.

SCURLOCK DRAFTING & DESIGN DOES NOT ASSUME LIABILITY FOR ANY ERRORS OR OMISSIONS ON THESE PLANS AFTER THE START OF CONSTRUCTION.

Plans Scaled For
24"x36" Paper

SCURLOCK
DRAFTING & DESIGN

4732 Concordia Dr.
Bryan, Tx 77802
L-7_B-22-S-7 of Miramont

KINSLINGTON HOMES

Floor Plan
SCALE: 1" = 1/4"

DATE:
1/10/2025
SHEET:
A-1

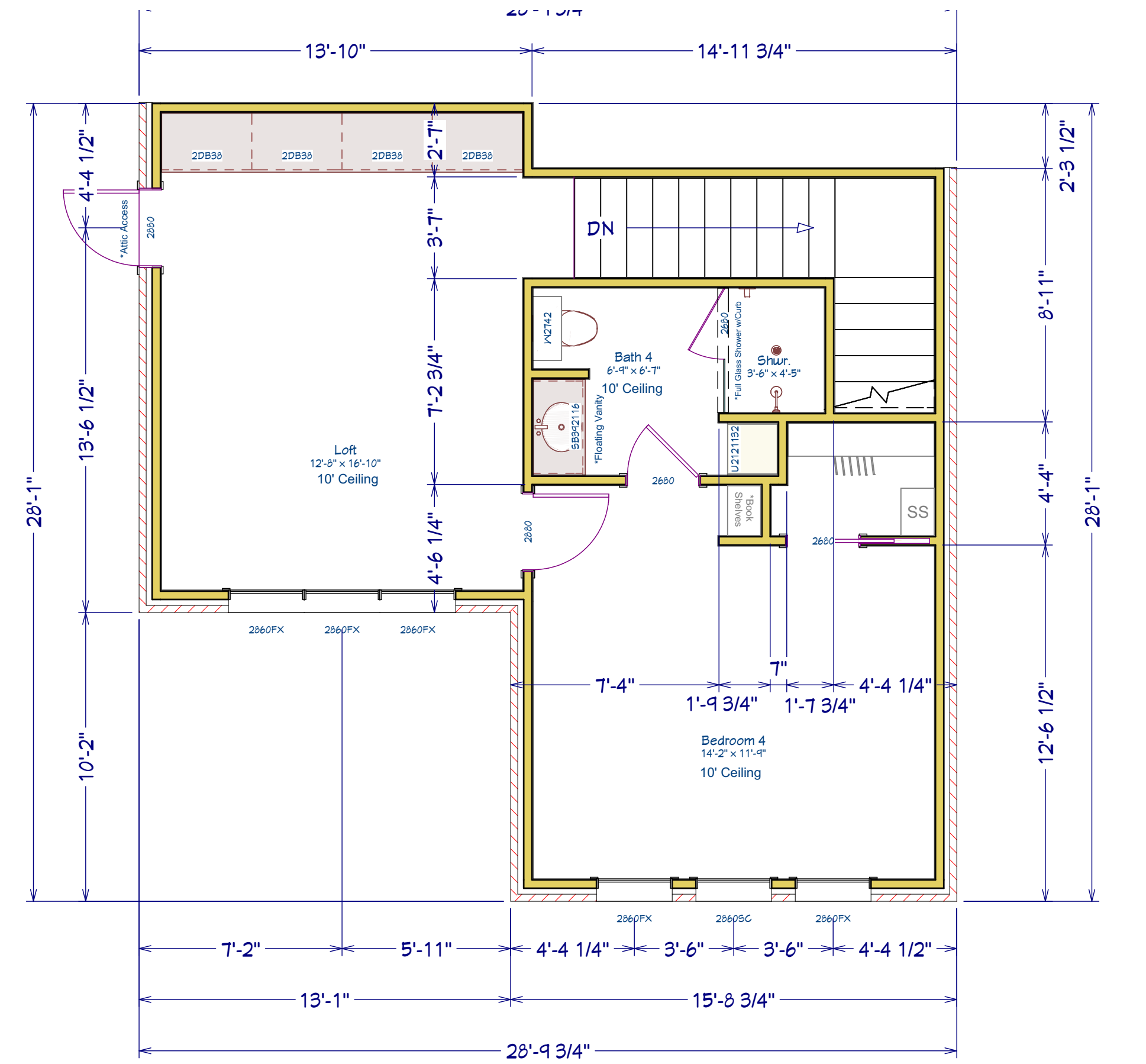
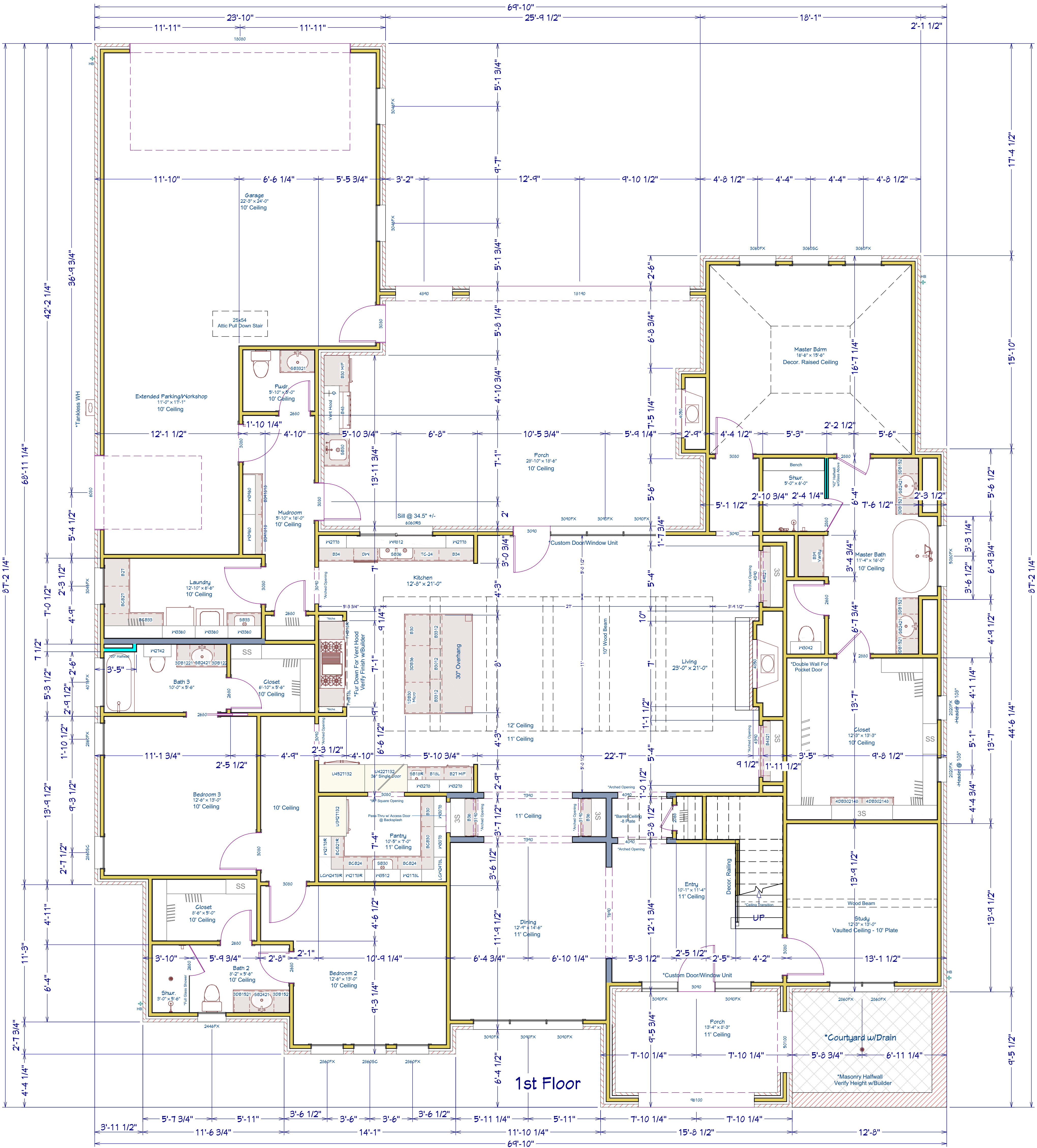

2nd Floor

Slab Area	4781 sq.ft.
Heated Area - 1st Floor	3222 sq.ft.
Heated Area - 2nd Floor	533 sq.ft.
Total Area	3755 sq.ft.
Garage Area	833 sq.ft.
Porch Area	126 sq.ft.
Courtyard Area	120 sq.ft.

ALL DRAWINGS, PLANS, AND SPECIFICATIONS ARE PROPERTY OF SCURLOCK DRAFTING & DESIGN. PURCHASER'S RIGHT IS CONDITIONAL AND LIMITED TO A ONE-TIME USE TO CONSTRUCT A SINGLE PROJECT ON THE LOT STATED HEREIN. THE USE OF OR REPRODUCTION OF THESE PLANS CONCERNING ANY OTHER CONSTRUCTION IS STRICTLY PROHIBITED. SCURLOCK DRAFTING & DESIGN IS NOT AN ENGINEERING FIRM NOR AN ARCHITECTURAL FIRM. SCURLOCK DRAFTING & DESIGN IS NOT QUALIFIED NOR LICENSED TO DESIGN STRUCTURAL FRAMING OR FOUNDATIONS. A LICENSED PROFESSIONAL ENGINEER SHOULD BE CONSULTED REGARDING STRUCTURAL FRAMING AND FOUNDATIONS. SHOULD AN ENGINEER'S SEAL BE PRESENT ON THE DRAWING, THEN THE "ENGINEER OF RECORD" SHALL BEAR THE SOLE RESPONSIBILITY FOR THE STRUCTURAL DESIGN. SCURLOCK DRAFTING & DESIGN WILL NOT BE HELD RESPONSIBLE FOR THE STRUCTURAL DESIGN AND/OR ANY PROBLEMS THAT MAY ARISE REGARDING THE DESIGN.

SCURLOCK DRAFTING ASSUMES NO LIABILITY FOR ANY HOME BUILT FROM THESE PLANS. IT IS THE RESPONSIBILITY OF THE BUILDER OF THESE PLANS TO PERFORM THE FOLLOWING BEFORE CONSTRUCTION BEGINS.

- VERIFY/BUILD TO LOCAL AND STATE CODES.
- ALL DIMENSIONS ARE TO BE CHECKED AND VERIFIED BEFORE CONSTRUCTION.
- VERIFY WINDOW SIZES WITH WINDOW MANUFACTURER FOR COMPLIANCE WITH INGRESS/EGRESS REQUIREMENTS.

SCURLOCK DRAFTING & DESIGN DOES NOT ASSUME LIABILITY FOR ANY ERRORS OR OMISSIONS ON THESE PLANS AFTER THE START OF CONSTRUCTION.

IT IS THE RESPONSIBILITY OF THE BUILDER TO PERFORM THE FOLLOWING BEFORE CONSTRUCTION BEGINS.

- VERIFY ALL SITE/LOT MEASUREMENTS.
- VERIFY BUILDING ENVELOPE AND FOUNDATION LOCATION.
- VERIFY ALL SITE/LOT BUILDING SETBACK REQUIREMENTS IN CORRESPONDENCE WITH CITY AND NEIGHBOR DEED RESTRICTIONS.
- VERIFY LOCATION OF ALL PUBLIC AND PRIVATE EASEMENTS.

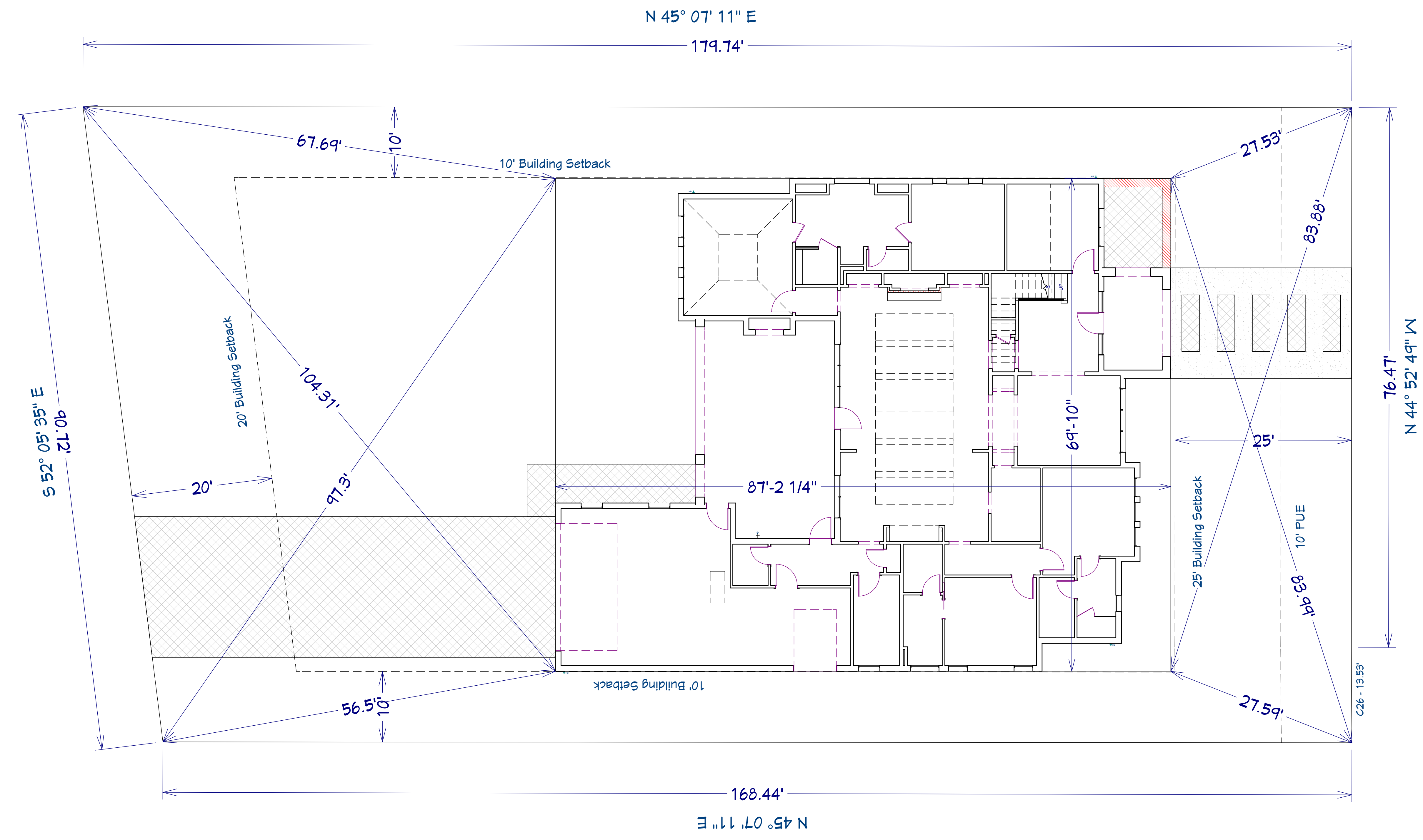

Plans Scaled For
24"x36" Paper



4732 Concordia Dr.
Bryan, Tx 77802
L-7 B-22-S-7 of Miramont

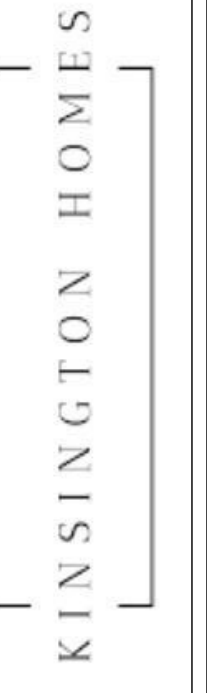

Site
SCALE: 1" = 1/8"

DATE:

1/10/2025

SHEET:

A-2

ALL DRAWINGS, PLANS, AND SPECIFICATIONS ARE PROPERTY OF SCURLOCK DRAFTING & DESIGN. PURCHASER'S RIGHT IS CONDITIONAL AND LIMITED TO A ONE-TIME USE TO CONSTRUCT A SINGLE PROJECT ON THE LOT STATED HEREIN. THE USE OF OR REPRODUCTION OF THESE PLANS CONCERNING ANY OTHER CONSTRUCTION IS STRICTLY PROHIBITED. SCURLOCK DRAFTING & DESIGN IS NOT AN ENGINEERING FIRM NOR AN ARCHITECTURAL FIRM. SCURLOCK DRAFTING & DESIGN IS NOT QUALIFIED NOR LICENSED TO DESIGN STRUCTURAL FRAMING OR FOUNDATIONS. A LICENSED PROFESSIONAL ENGINEER SHOULD BE CONSULTED REGARDING STRUCTURAL FRAMING AND FOUNDATIONS. SHOULD AN ENGINEER'S SEAL BE PRESENT ON THE DRAWING, THEN THE "ENGINEER OF RECORD" SHALL BEAR THE SOLE RESPONSIBILITY FOR THE STRUCTURAL DESIGN. SCURLOCK DRAFTING & DESIGN WILL NOT BE HELD RESPONSIBLE FOR THE STRUCTURAL DESIGN AND/OR ANY PROBLEMS THAT MAY ARISE REGARDING THE DESIGN.

SCURLOCK DRAFTING ASSUMES NO LIABILITY FOR ANY HOME BUILT FROM THESE PLANS. IT IS THE RESPONSIBILITY OF THE BUILDER OF THESE PLANS TO PERFORM THE FOLLOWING BEFORE CONSTRUCTION BEGINS.

- VERIFY/BUILD TO LOCAL AND STATE CODES.
- ALL DIMENSIONS ARE TO BE CHECKED AND VERIFIED BEFORE CONSTRUCTION.
- VERIFY WINDOW SIZES WITH WINDOW MANUFACTURER FOR COMPLIANCE WITH INGRESS/EGRESS REQUIREMENTS.

SCURLOCK DRAFTING & DESIGN DOES NOT ASSUME LIABILITY FOR ANY ERRORS OR OMISSIONS ON THESE PLANS AFTER THE START OF CONSTRUCTION.



Front Elevation



Rear Elevation

Plans Scaled For
24"x36" Paper

SCURLOCK
DRAFTING & DESIGN

4732 Concordia Dr.
Bryan, Tx 77802
L-7_B-22-S-7 of Miramont

K I N S I N G T O N H O M E S

Elevations
SCALE: 1" = 1/4"

DATE:

1/10/2025

SHEET:

A-3

ALL DRAWINGS, PLANS, AND SPECIFICATIONS ARE PROPERTY OF SCURLOCK DRAFTING & DESIGN. PURCHASER'S RIGHT IS CONDITIONAL AND LIMITED TO A ONE-TIME USE TO CONSTRUCT A SINGLE PROJECT ON THE LOT STATED HEREIN. THE USE OF OR REPRODUCTION OF THESE PLANS CONCERNING ANY OTHER CONSTRUCTION IS STRICTLY PROHIBITED. SCURLOCK DRAFTING & DESIGN IS NOT AN ENGINEERING FIRM NOR AN ARCHITECTURAL FIRM. SCURLOCK DRAFTING & DESIGN IS NOT QUALIFIED NOR LICENSED TO DESIGN STRUCTURAL FRAMING OR FOUNDATIONS. A LICENSED PROFESSIONAL ENGINEER SHOULD BE CONSULTED REGARDING STRUCTURAL FRAMING AND FOUNDATIONS. SHOULD AN ENGINEER'S SEAL BE PRESENT ON THE DRAWING, THEN THE "ENGINEER OF RECORD" SHALL BEAR THE SOLE RESPONSIBILITY FOR THE STRUCTURAL DESIGN. SCURLOCK DRAFTING & DESIGN WILL NOT BE HELD RESPONSIBLE FOR THE STRUCTURAL DESIGN AND/OR ANY PROBLEMS THAT MAY ARISE REGARDING THE DESIGN.

SCURLOCK DRAFTING ASSUMES NO LIABILITY FOR ANY HOME BUILT FROM THESE PLANS. IT IS THE RESPONSIBILITY OF THE BUILDER OF THESE PLANS TO PERFORM THE FOLLOWING BEFORE CONSTRUCTION BEGINS.

- VERIFY/BUILD TO LOCAL AND STATE CODES.
- ALL DIMENSIONS ARE TO BE CHECKED AND VERIFIED BEFORE CONSTRUCTION.
- VERIFY WINDOW SIZES WITH WINDOW MANUFACTURER FOR COMPLIANCE WITH INGRESS/EGRESS REQUIREMENTS.

SCURLOCK DRAFTING & DESIGN DOES NOT ASSUME LIABILITY FOR ANY ERRORS OR OMISSIONS ON THESE PLANS AFTER THE START OF CONSTRUCTION.



Left Elevation

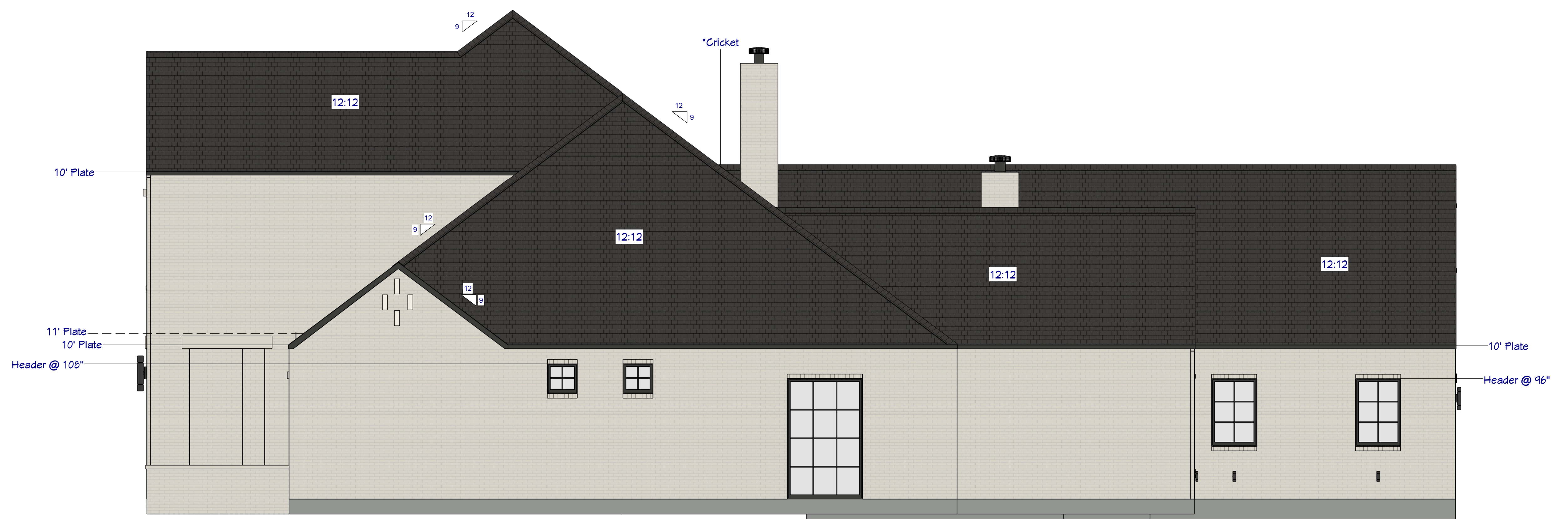

Right Elevation

Plans Scaled For
24"x36" Paper



4732 Concordia Dr.
Bryan, Tx 77802
L-7 B-22.5-7 of Miramont

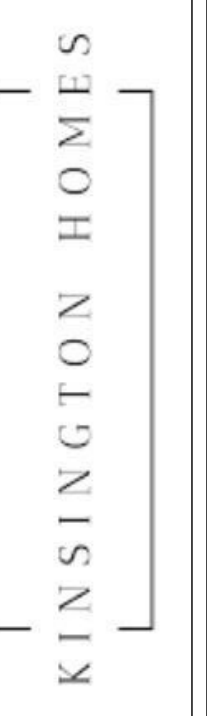

Elevations
SCALE: 1" = 1/4"

DATE:

1/10/2025

SHEET:

A-4

ALL DRAWINGS, PLANS, AND SPECIFICATIONS ARE PROPERTY OF SCURLOCK DRAFTING & DESIGN. PURCHASER'S RIGHT IS CONDITIONAL AND LIMITED TO A ONE-TIME USE TO CONSTRUCT A SINGLE PROJECT ON THE LOT STATED HEREIN. THE USE OF OR REPRODUCTION OF THESE PLANS CONCERNING ANY OTHER CONSTRUCTION IS STRICTLY PROHIBITED. SCURLOCK DRAFTING & DESIGN IS NOT AN ENGINEERING FIRM NOR AN ARCHITECTURAL FIRM. SCURLOCK DRAFTING & DESIGN IS NOT QUALIFIED NOR LICENSED TO DESIGN STRUCTURAL FRAMING OR FOUNDATIONS. A LICENSED PROFESSIONAL ENGINEER SHOULD BE CONSULTED REGARDING STRUCTURAL FRAMING AND FOUNDATIONS. SHOULD AN ENGINEER'S SEAL BE PRESENT ON THE DRAWING, THEN THE "ENGINEER OF RECORD" SHALL BEAR THE SOLE RESPONSIBILITY FOR THE STRUCTURAL DESIGN. SCURLOCK DRAFTING & DESIGN WILL NOT BE HELD RESPONSIBLE FOR THE STRUCTURAL DESIGN AND/OR ANY PROBLEMS THAT MAY ARISE REGARDING THE DESIGN.

SCURLOCK DRAFTING ASSUMES NO LIABILITY FOR ANY HOME BUILT FROM THESE PLANS. IT IS THE RESPONSIBILITY OF THE BUILDER OF THESE PLANS TO PERFORM THE FOLLOWING BEFORE CONSTRUCTION BEGINS.

- VERIFY/BUILD TO LOCAL AND STATE CODES.
- ALL DIMENSIONS ARE TO BE CHECKED AND VERIFIED BEFORE CONSTRUCTION.
- VERIFY WINDOW SIZES WITH WINDOW MANUFACTURER FOR COMPLIANCE WITH INGRESS/EGRESS REQUIREMENTS.

SCURLOCK DRAFTING & DESIGN DOES NOT ASSUME LIABILITY FOR ANY ERRORS OR OMISSIONS ON THESE PLANS AFTER THE START OF CONSTRUCTION.

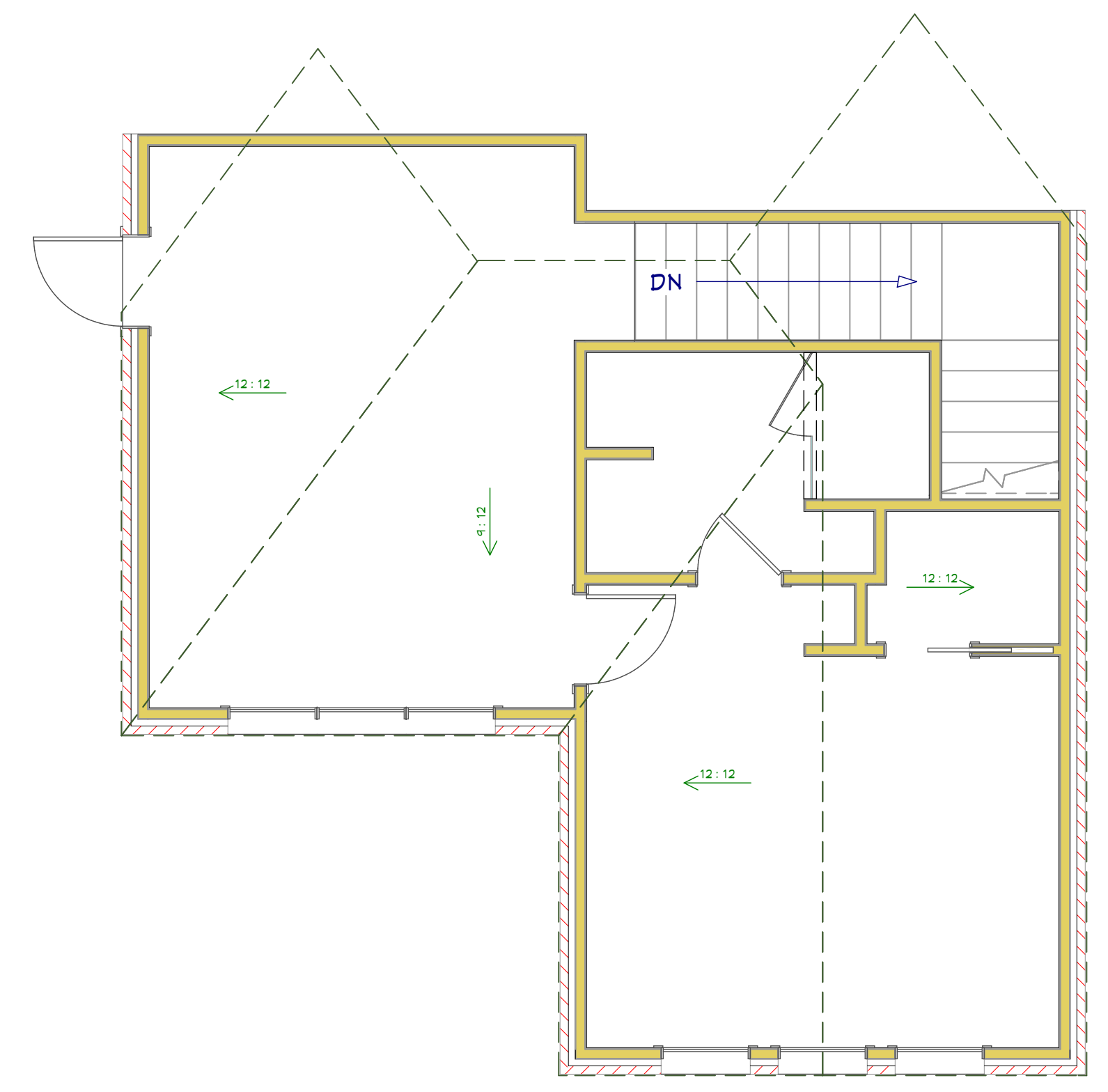
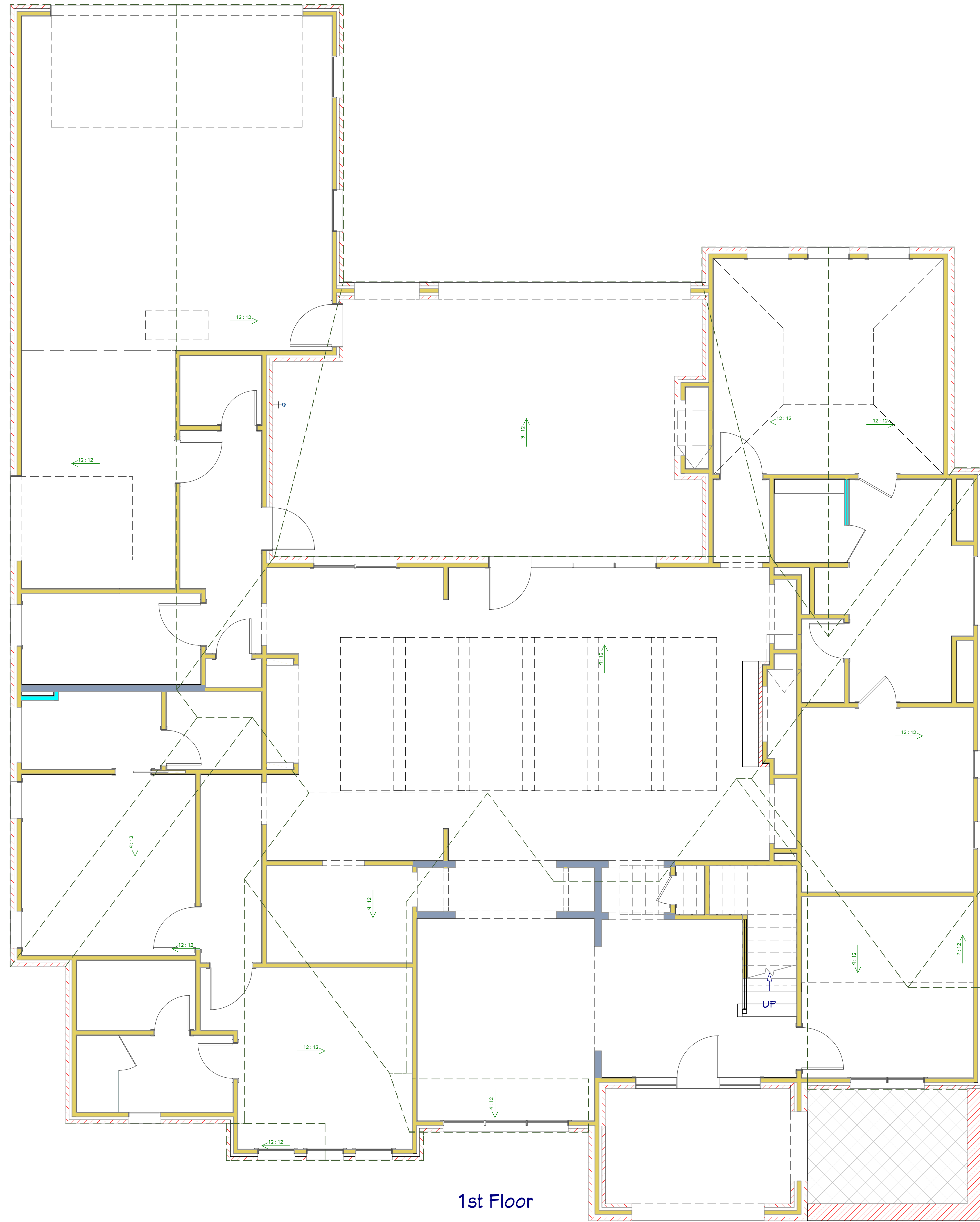

*No Soffit Overhang

Plans Scaled For
24"x36" Paper



4732 Concordia Dr.
Bryan, Tx 77802
L-7 B-22 S-7 of Miramont

KINGSTON HOMES

Roof Plan
SCALE: 1" = 1/4"

DATE:

1/10/2025

SHEET:

A-5

ELECTRICAL DATA & AUDIO NOTES:
HOME OWNER SHALL DO A WALK-THRU WITH RELEVANT INSTALLERS TO VERIFY THE EXACT LOCATION FOR OUTLETS, LIGHTS, SWITCHES, CABLE, DATA, PHONE, AUDIO, ETC.

- ELECTRICAL NOTES:**
1. ELECTRICAL RECEPTACLES IN BATHROOMS, KITCHENS AND GARAGES SHALL BE G.F.I. OR G.F.C. PER NATIONAL ELECTRICAL CODE REQUIREMENTS.
 2. PROVIDE ONE SMOKE DETECTOR IN EACH ROOM AND ONE IN EACH CORRIDOR ACCESSING BEDROOMS. CONNECT SMOKE DETECTORS TO HOUSE POWER AND INTER-CONNECT SMOKE DETECTORS SO THAT WHEN ANY ONE IS TRIPPED, THEY ALL WILL SOUND. PROVIDE BATTERY BACKUP FOR ALL UNITS.
 3. CIRCUITS SHALL BE VERIFIED WITH HOME OWNER PRIOR TO WIRE INSTALLATION.
 4. FINAL SWITCHES FOR TIMERS AND DIMMERS SHALL BE VERIFIED WITH HOME OWNER.
 5. FIXTURES TO BE SELECTED BY HOME OWNER.

- AUDIO:**
1. LOCATE SPEAKERS AND AUDIO CONTROLS AS INDICATED IN THE PLAN; RUN CIRCUIT OF SPEAKER WIRING TO AUDIO HOME PANEL SPECIFIED BY FLOOR.
 2. AUDIO SPEAKERS TO BE APPROVED BY HOME OWNER.
 3. LOCATE JACKS AS INDICATED IN THE PLAN; INSTALL DATA / CABLE PANEL SIMILAR TO "ON Q". SYSTEM TO BE APPROVED BY HOME OWNER.

DATA / CABLE:
LOCATE SECURITY PANELS AS INDICATED IN THE PLAN; SYSTEM TO BE APPROVED BY HOME OWNER.

ELECTRICAL - DATA - AUDIO LEGEND	
SYMBOL	DESCRIPTION
	Ceiling Fan
	Ventilation Fans: Ceiling Mounted, Wall Mounted
	Ceiling Mounted Light Fixtures: Surface/Pendant, Recessed, Heat Lamp, Low Voltage
	Wall Mounted Light Fixtures: Flush Mounted, Wall Sconce
	Chandelier Light Fixture
	Fluorescent Light Fixture
	240V Receptacle
	110V Receptacles: Duplex, Weather Proof, GFCI
	Switches: Single Pole, Weather Proof, 3-Way, 4-Way
	Switches: Dimmer, Timer
	Audio Video: Control Panel, Switch
	Speakers: Ceiling Mounted, Wall Mounted
	Wall Jacks: CAT5, CAT5 + TV, TV/Cable
	Telephone Jack
	Intercom
	Thermostat
	Door Chime, Door Bell Button
	Smoke Detectors: Ceiling Mounted, Wall Mounted
	Electrical Breaker Panel

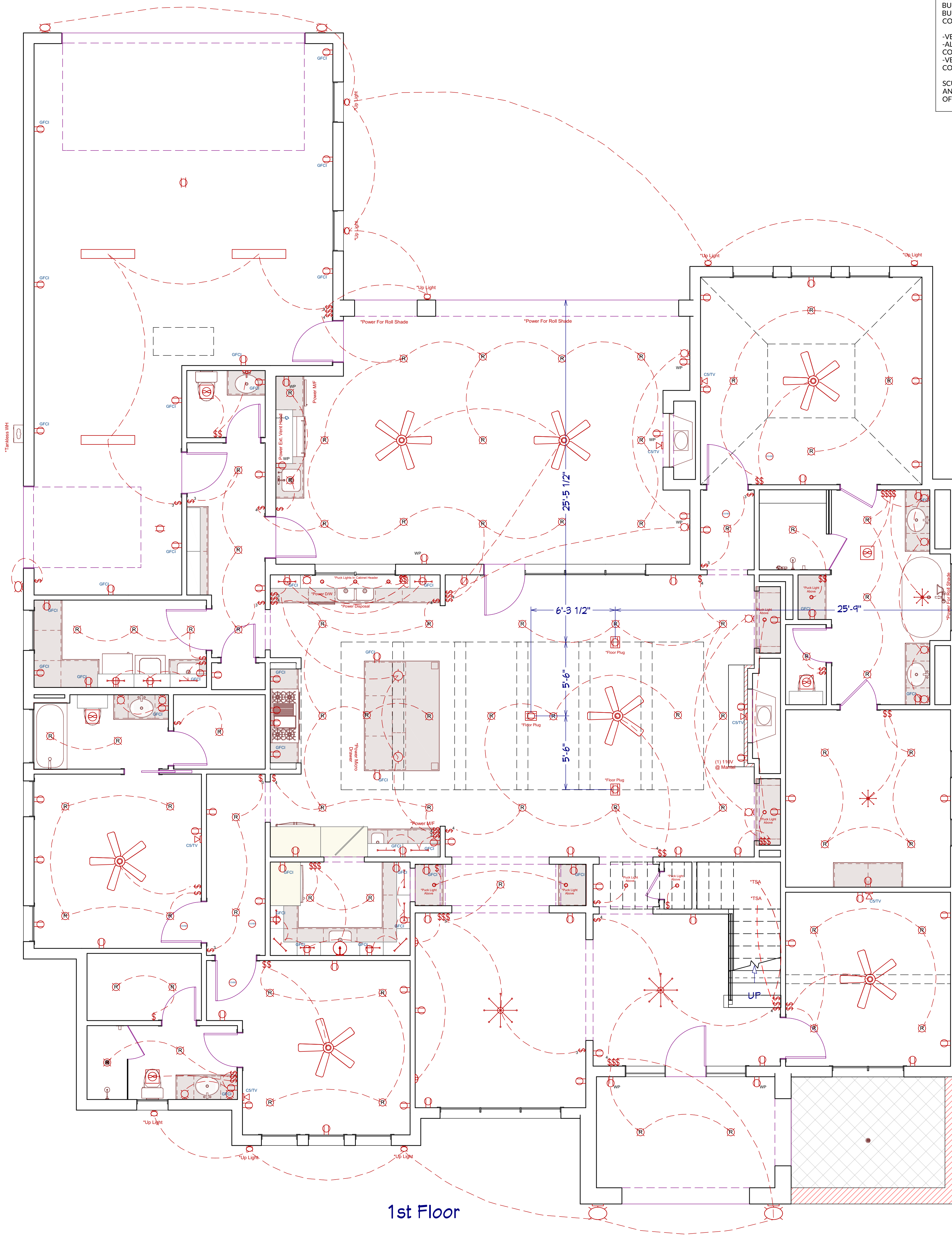

SCURLOCK DRAFTING ASSUMES NO LIABILITY FOR ANY HOME BUILT FROM THESE PLANS. IT IS THE RESPONSIBILITY OF THE BUILDER OF THESE PLANS TO PERFORM THE FOLLOWING BEFORE CONSTRUCTION BEGINS.

- VERIFY/BUILD TO LOCAL AND STATE CODES.
- ALL DIMENSIONS ARE TO BE CHECKED AND VERIFIED BEFORE CONSTRUCTION.
- VERIFY WINDOW SIZES WITH WINDOW MANUFACTURER FOR COMPLIANCE WITH INGRESS/EGRESS REQUIREMENTS.

SCURLOCK DRAFTING & DESIGN DOES NOT ASSUME LIABILITY FOR ANY ERRORS OR OMISSIONS ON THESE PLANS AFTER THE START OF CONSTRUCTION.

ALL DRAWINGS, PLANS, AND SPECIFICATIONS ARE PROPERTY OF SCURLOCK DRAFTING & DESIGN. PURCHASER'S RIGHT IS CONDITIONAL AND LIMITED TO A ONE-TIME USE TO CONSTRUCT A SINGLE PROJECT ON THE LOT STATED HEREIN. THE USE OF OR REPRODUCTION OF THESE PLANS CONCERNING ANY OTHER CONSTRUCTION IS STRICTLY PROHIBITED. SCURLOCK DRAFTING & DESIGN IS NOT AN ENGINEERING FIRM NOR AN ARCHITECTURAL FIRM. SCURLOCK DRAFTING & DESIGN IS NOT QUALIFIED NOR LICENSED TO DESIGN STRUCTURAL FRAMING OR FOUNDATIONS. A LICENSED PROFESSIONAL ENGINEER SHOULD BE CONSULTED REGARDING STRUCTURAL FRAMING AND FOUNDATIONS. SHOULD AN ENGINEER'S SEAL BE PRESENT ON THE DRAWING, THEN THE "ENGINEER OF RECORD" SHALL BEAR THE SOLE RESPONSIBILITY FOR THE STRUCTURAL DESIGN. SCURLOCK DRAFTING & DESIGN WILL NOT BE HELD RESPONSIBLE FOR THE STRUCTURAL DESIGN AND/OR ANY PROBLEMS THAT MAY ARISE REGARDING THE DESIGN.

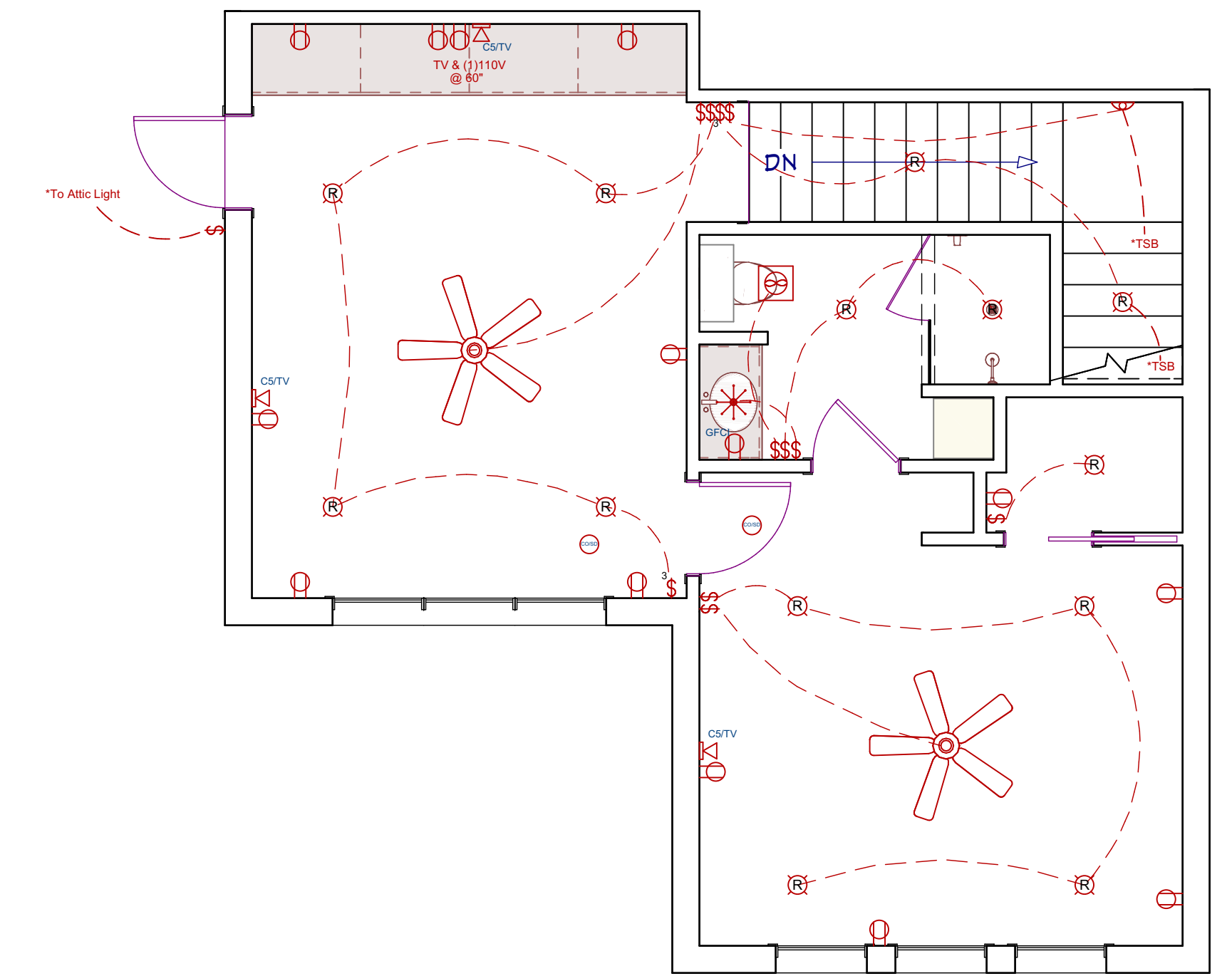

2nd Floor

1st Floor

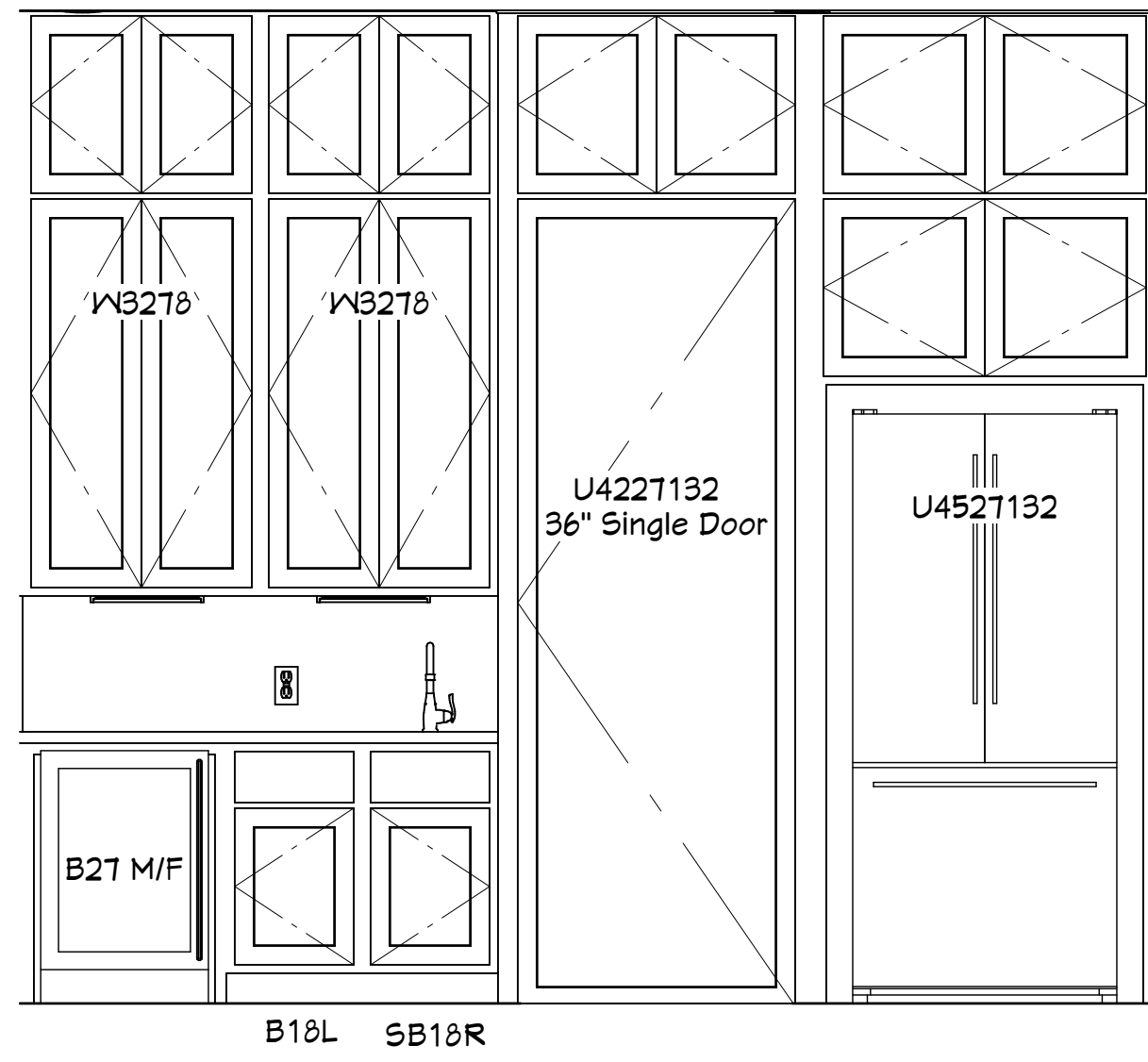

Kitchen 1

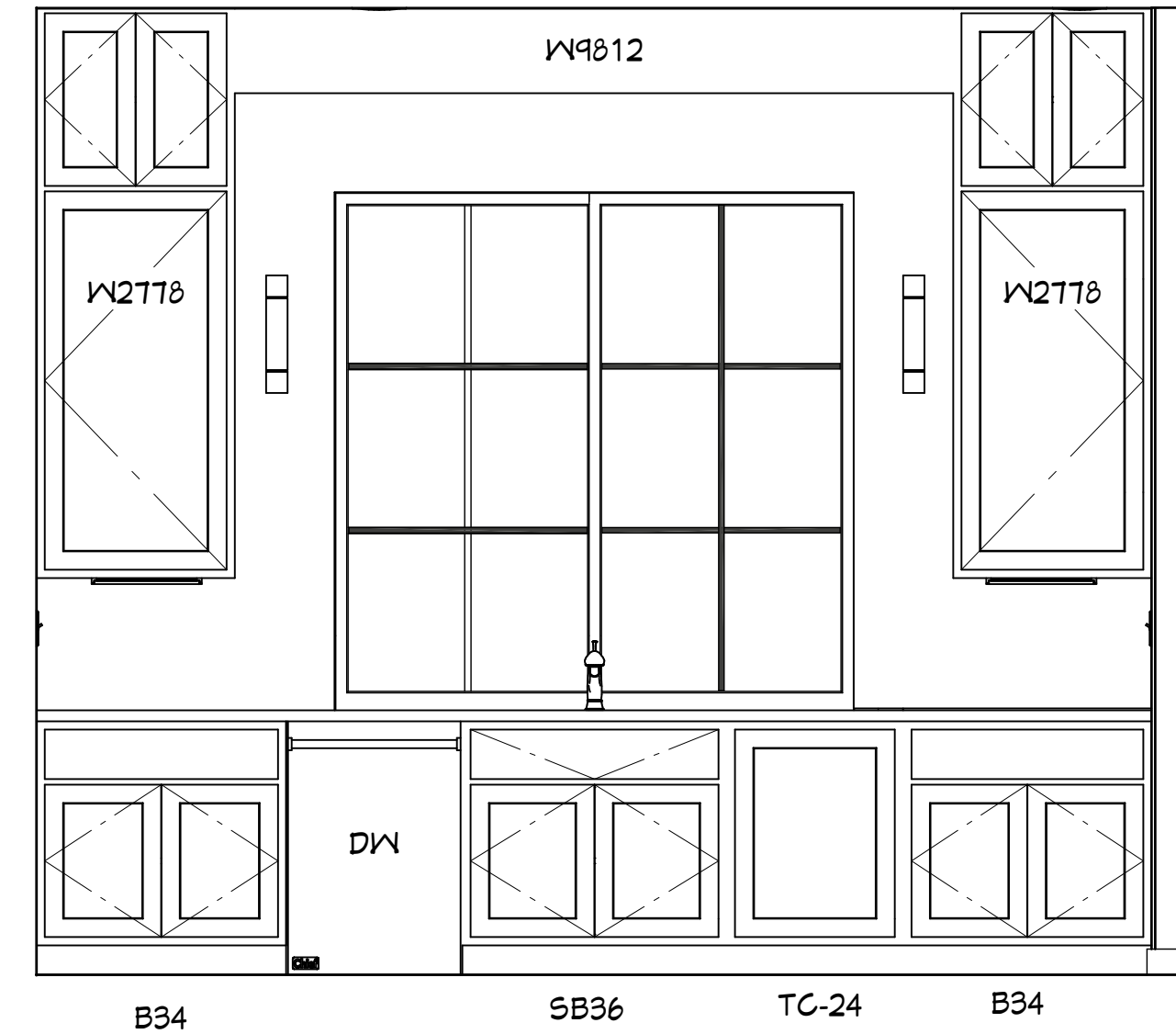

Kitchen 2

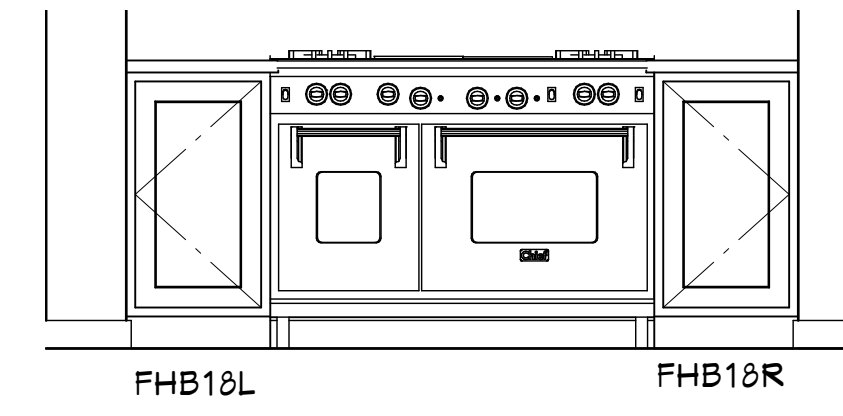

Kitchen 3

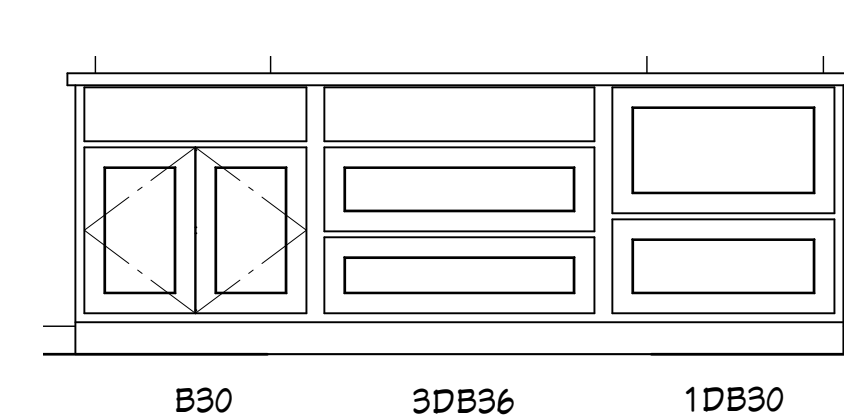

Island 1

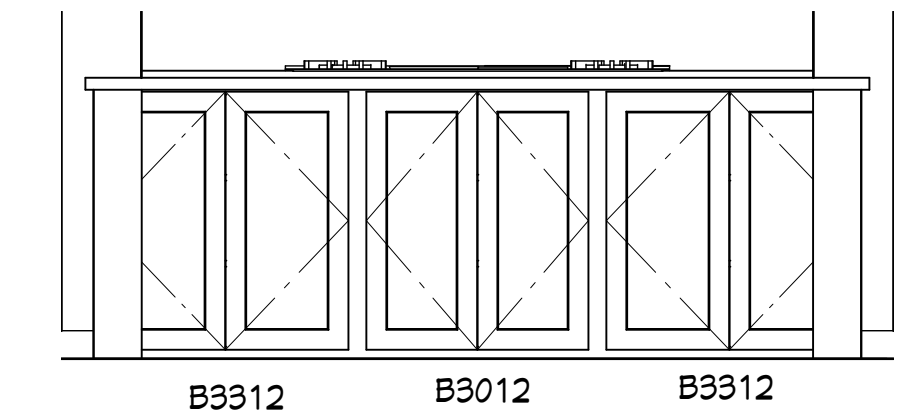

Island 2

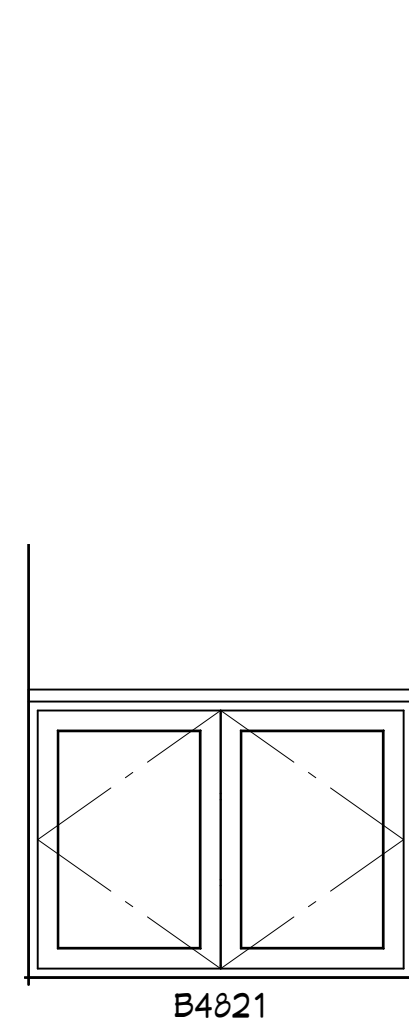

Living Room

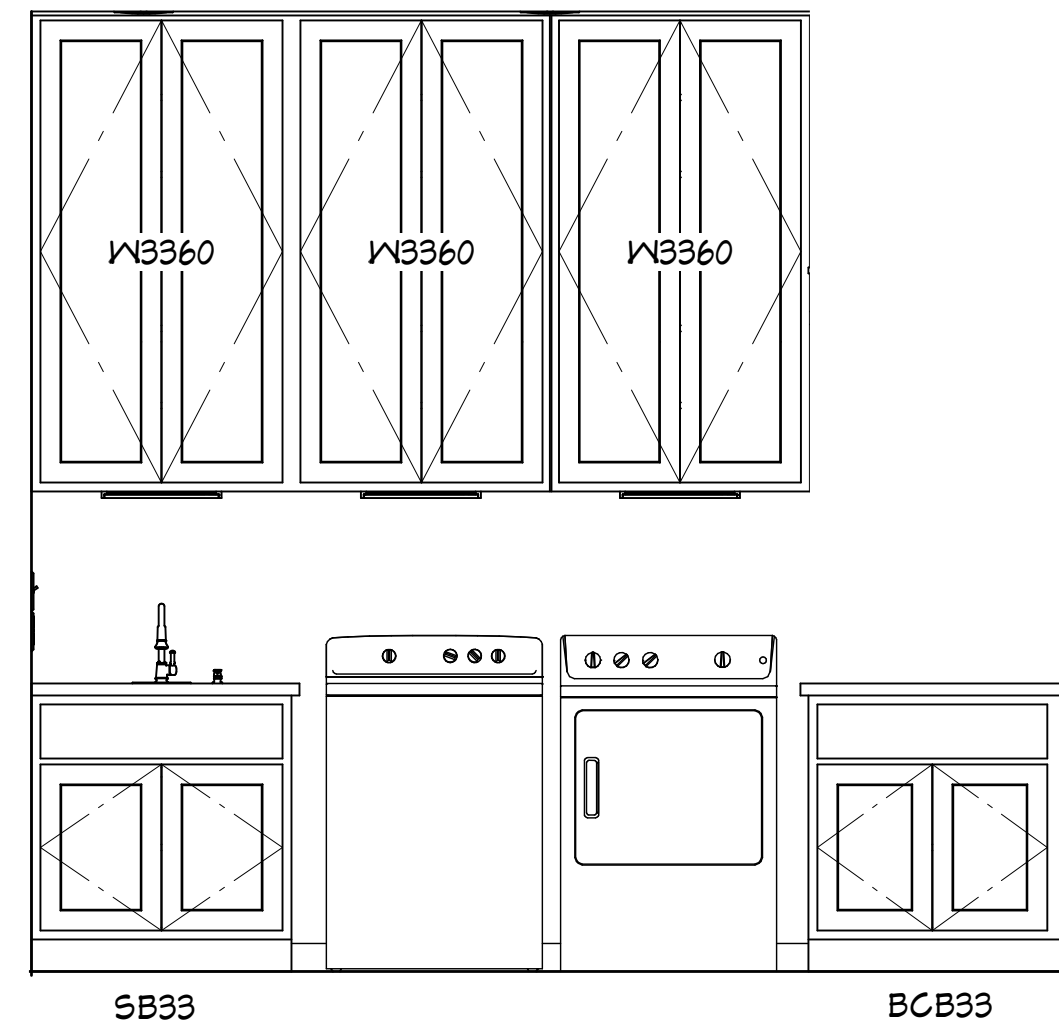

Laundry 1

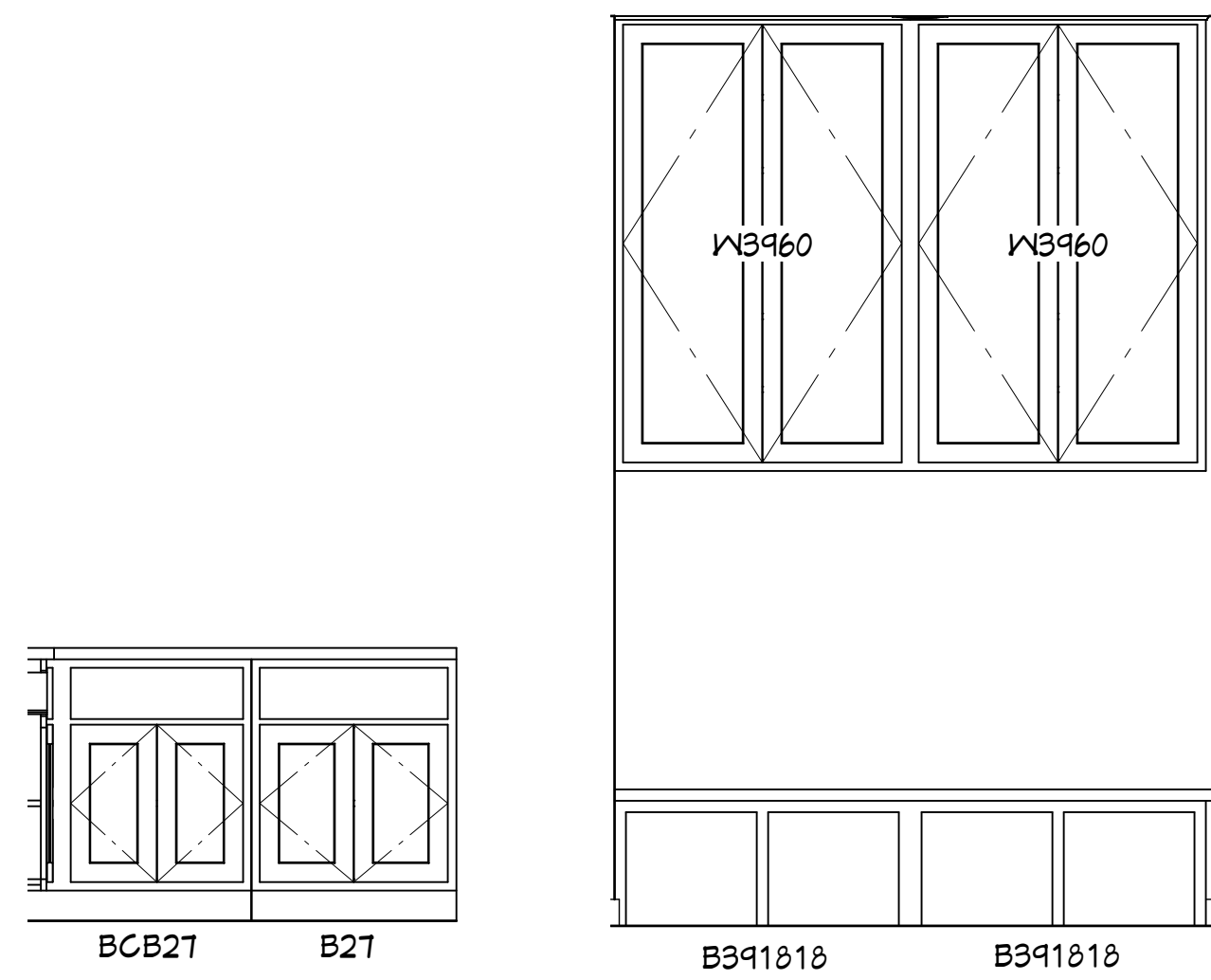

Mudroom

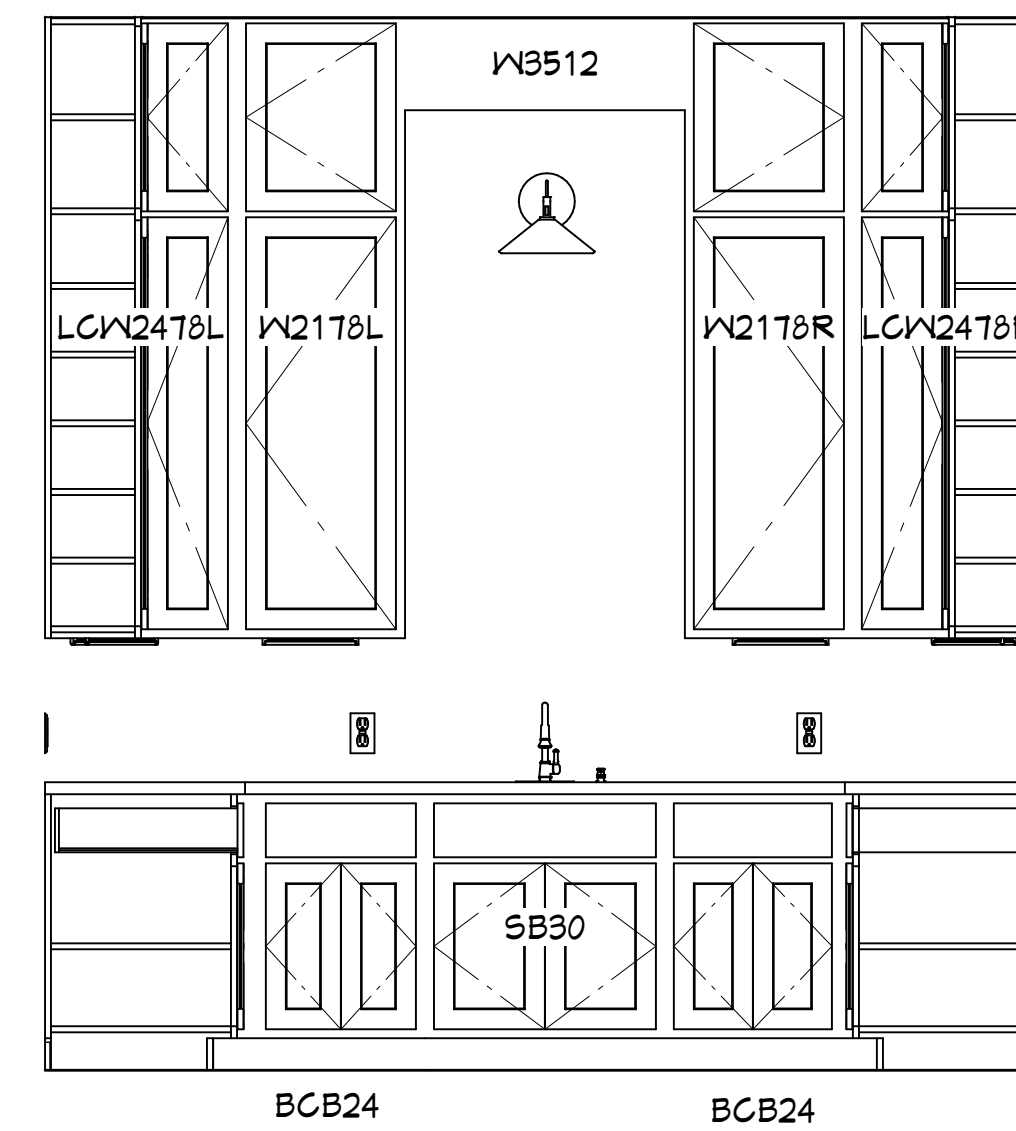

Pantry 1

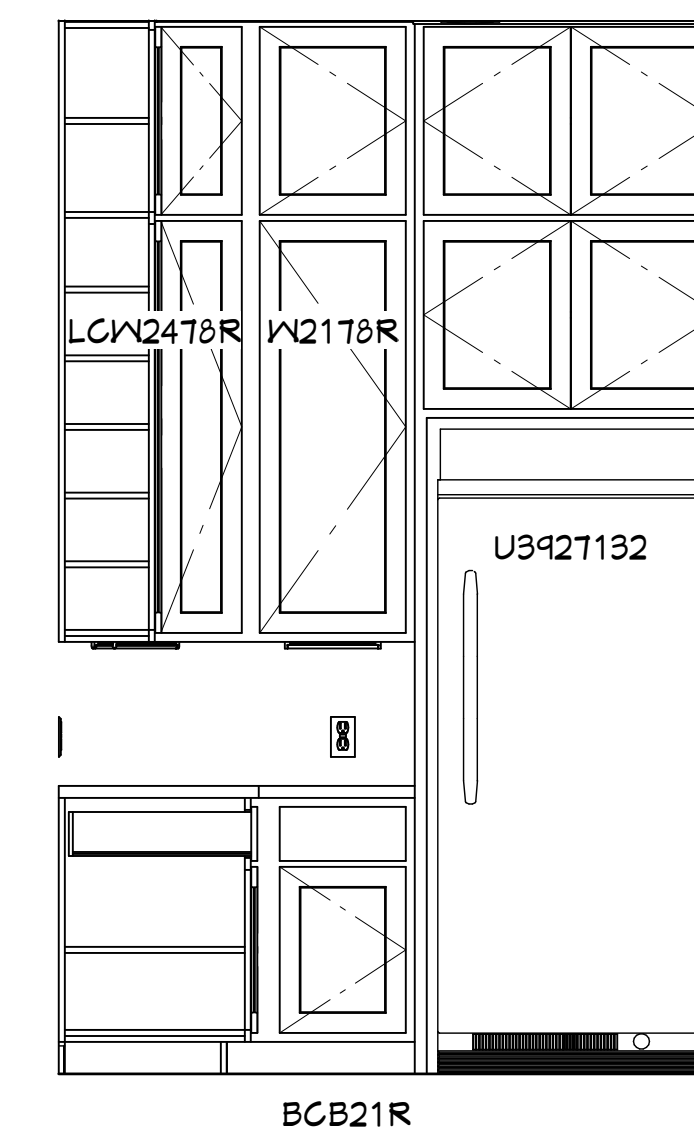

Pantry 2



Pantry 3

Butler's

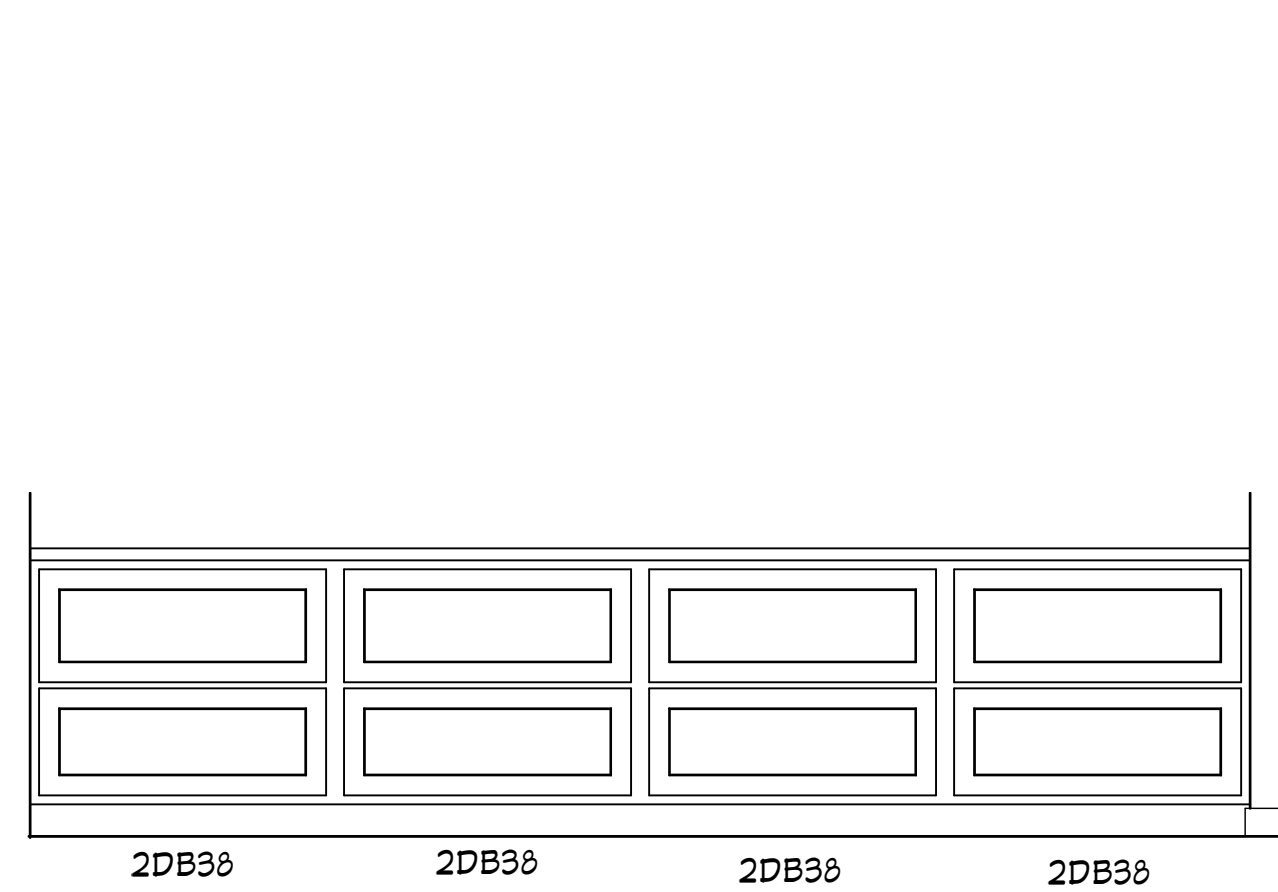

Loft

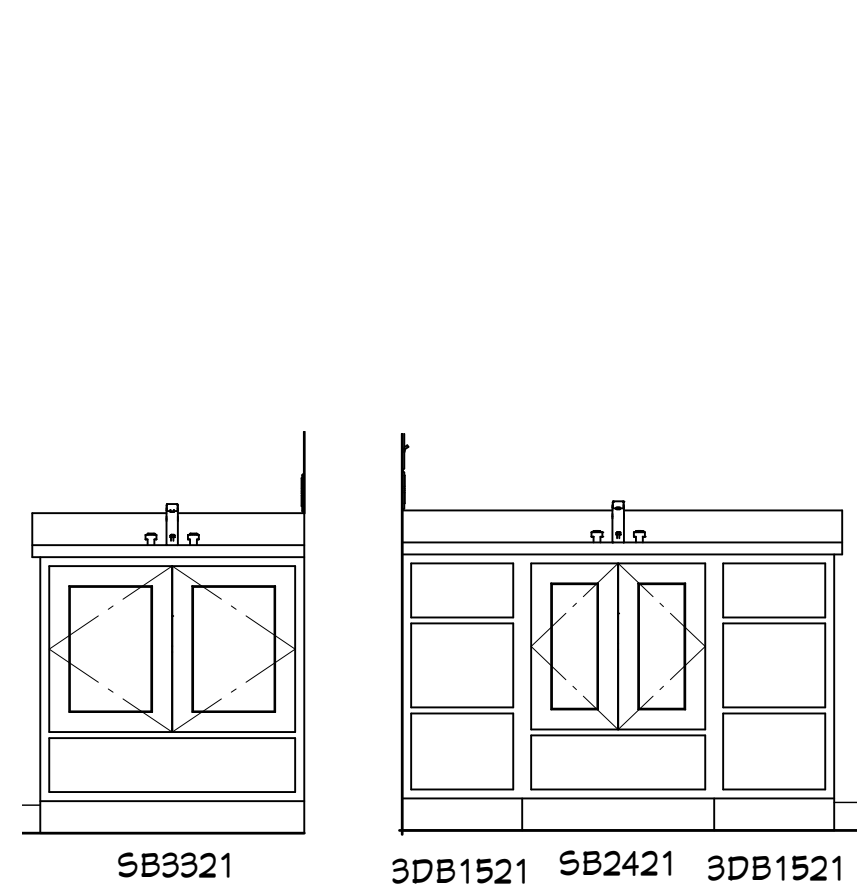

Powdr.

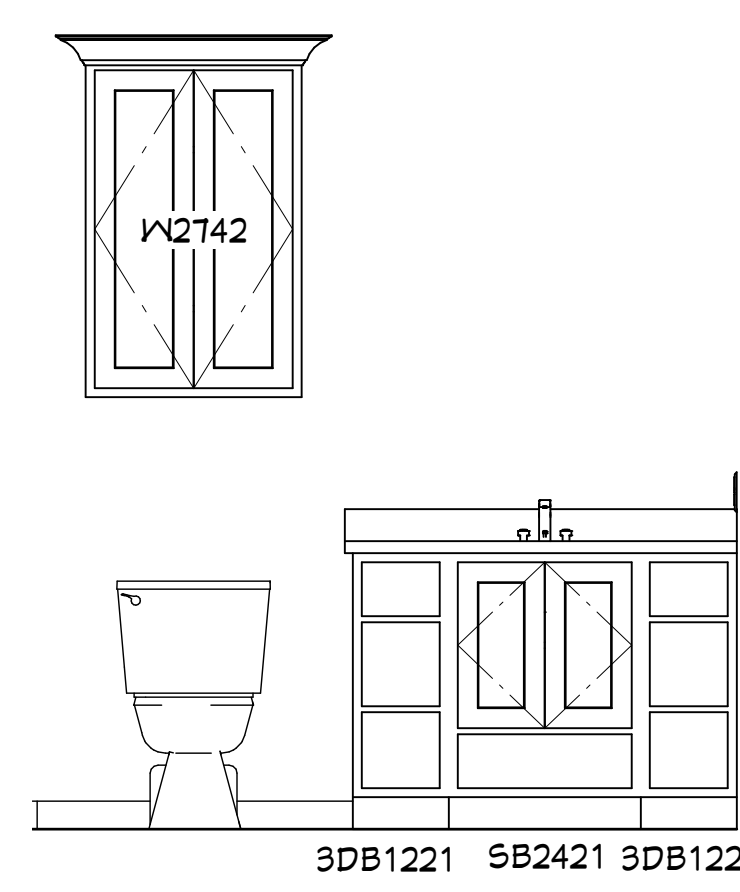

Bath 2

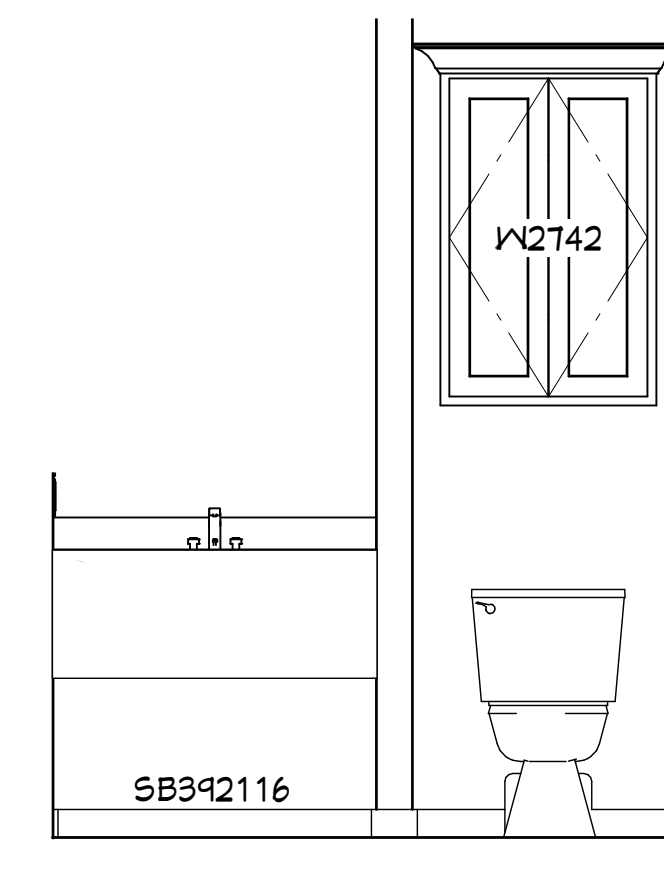

Bath 3

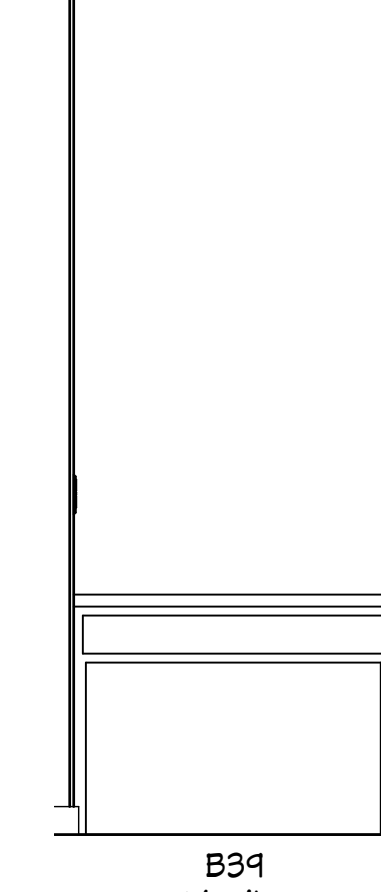

M. Bath Vanity

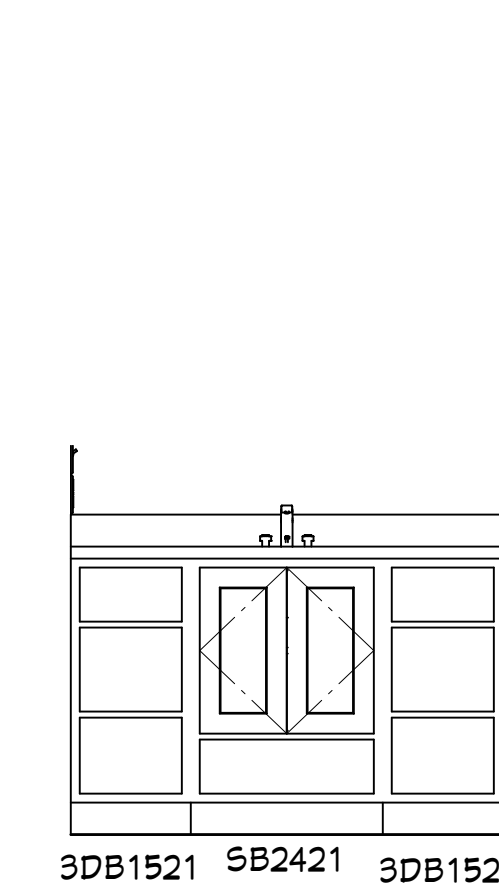

M. Bath

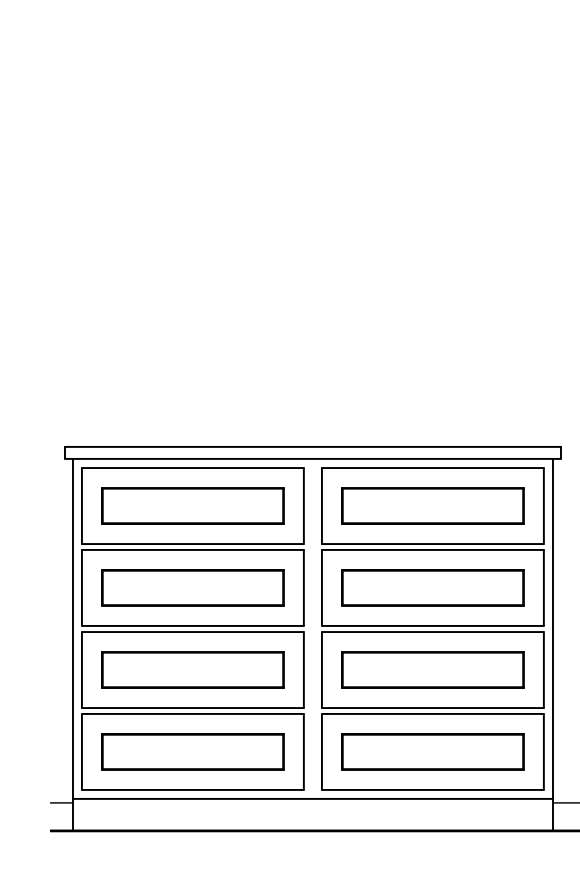

M. Closet

